

**RoHS Compliance**

REFER TO DL GROUP GREEN PROCUREMENT GUIDE LINE (DL-EMS-010\_).

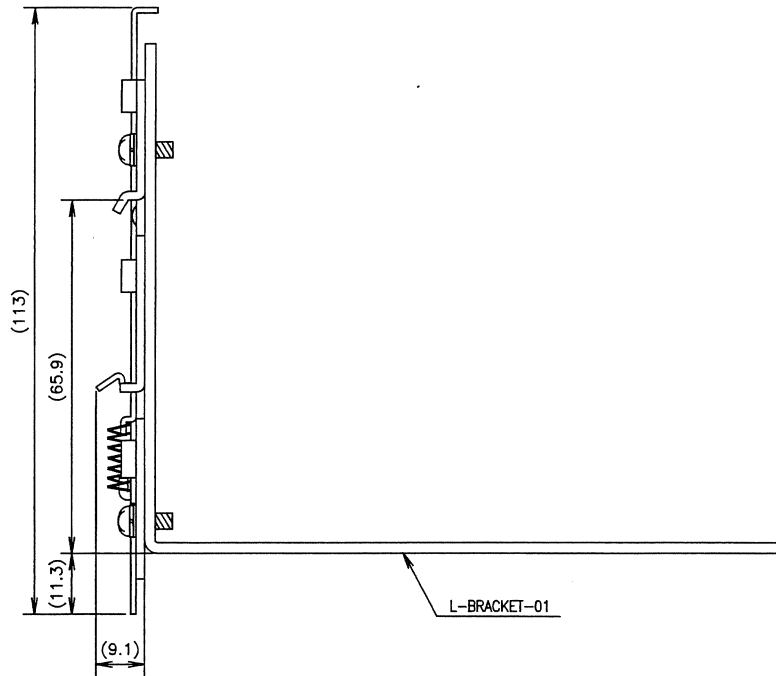
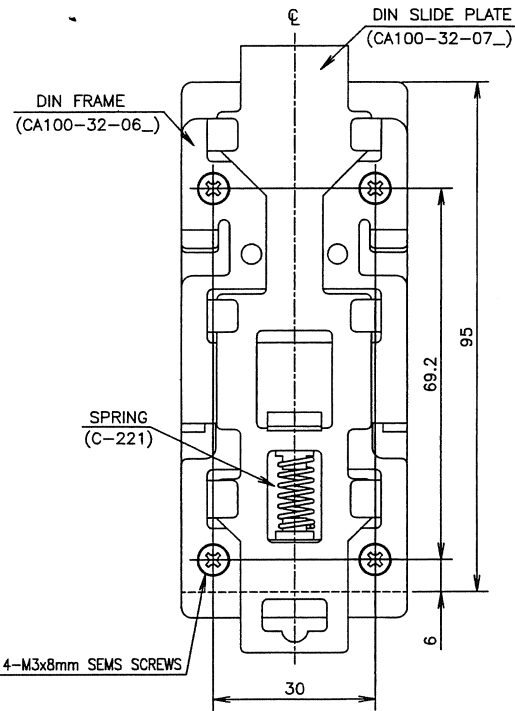
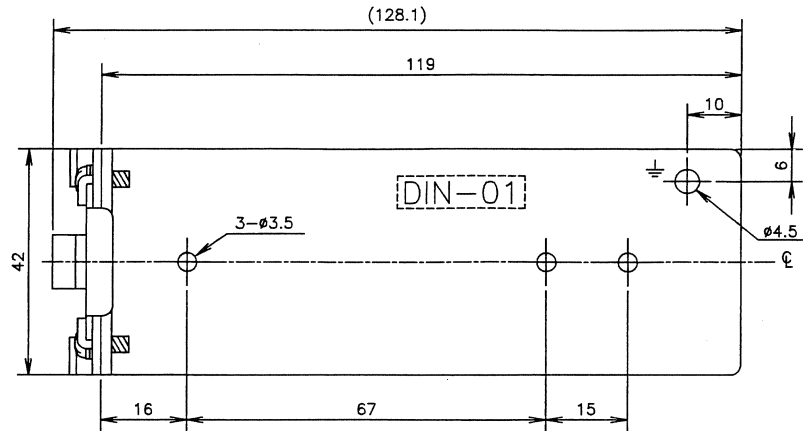

**PARTS LIST**

|   | PARTS LIST      | CATALOG No.                           | NET | MANUFACTURE |
|---|-----------------|---------------------------------------|-----|-------------|
| 1 | DIN FRAME       | CA100-32-06_<br>(ONWARD CA100-32-06C) | 1   | D-L         |
| 2 | DIN SLIDE PLATE | CA100-32-07_<br>(ONWARD CA100-32-07C) | 1   | D-L         |
| 3 | L-BRACKET-01    | 8000-3-667_                           | 1   | D-L         |
| 4 | SPRING          | C-221                                 | 1   | KATO SPRING |
| 5 | SCREWS          | M3x8mm SEMS                           | 4   | D-L         |



|       |       |                  |                      |                                       |
|-------|-------|------------------|----------------------|---------------------------------------|
| SCALE | 1 / 1 | MATERIALS        | TITLE                | DIN-01(HWS15/30)                      |
| UNITS | mm    | SPCC-SD<br>t=2.0 |                      | MOUNTING PLATE                        |
|       |       | FINISH           | DRAWING No.          | 8000-3-664 - <input type="checkbox"/> |
|       |       |                  | <b>DENSEI-LAMBDA</b> |                                       |

|   |     |             |           |          |        |       |
|---|-----|-------------|-----------|----------|--------|-------|
| - | -1  | NEW RELEASE | 29/Jul/05 | Sh.Kondo | Fukuda | Shige |
| D | REV | CONTENTS    | DATE      | ENGR     | CHK    | APPD  |

R:\engineering\_control\other\8000\80003664.dwg